

ACL® CT-SVFI – SHX

Clamp Type Sterile Visual Flow Indicator



The **CT-SVFI** is a novel sight glass that has been designed with hygienic processing in mind. The glass/o-ring/flange end is sealed utilising a sanitary clamp. As there is a mechanical stop, the gasket cannot be over compressed. The use of a clamp connection reduces the need for tools to assemble or disassemble the sight glass. Additional seals provide a secondary barrier to prevent the ingress of contaminants to the seal location.



Advantages

- Design is aseptic due to the addition of external o-ring
- Labyrinth design with capillary fluid barriers to halt external media migrating to process side
- Gasket compression is controlled with metal to metal contact
- Assembly / disassembly is very simple
- No large screw threads to clean – less COP time
- Force is applied in one direction to the gasket

Applications

- Pharmaceutical processing
- Food / dairy
- Chemical processing
- Can be welded in place and easily disassembled

Compliance

- EC 1935/2004, FDA CFR 21 177.2600 & USP VI <87> <88> Certified gaskets
- Surface finish according to ASME-BPE
- Controlled gasket extrusion to ASME-BPE CAT2
- Fully complies with the requirements of the European Pressure Equipment Directive 2014/68/EU and carries the 'CE' mark when so required
- Borosilicate glass 3.3 – pressure rating calculated according to CRN (FOS 10:1)

For further information contact:

> PHONE
+44(0)1535 669 216

> FAX
+44 (0)1535 610 243

> EMAIL
sales@advanced-couplings.com

ACL® CT-SVFI – SHX

Clamp Type Sterile Visual Flow Indicator

Dimensions

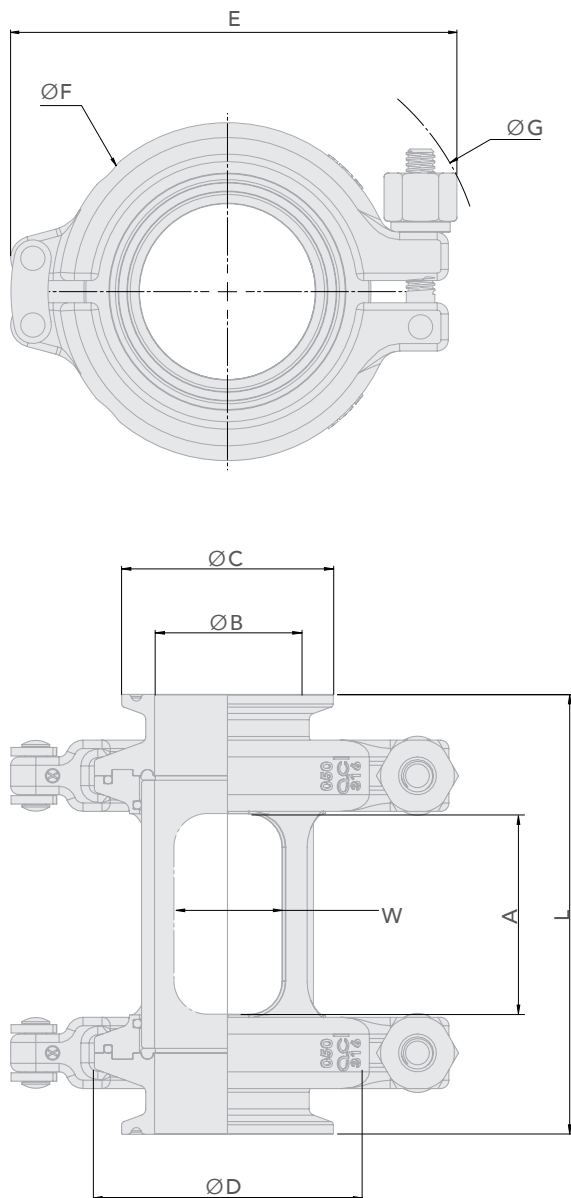

Clamp Type Sterile Visual Flow Indicators

Nominal size (inches)	DIMENSIONS (mm)										Working pressure (BAR)	Mass (kg)
	Window A x W	ID ØB	Mating flange ØC	Integral flange ØD	Length L	Width E	Minor OD ØF	Major OD ØG	Number of windows	Integral clamp size		
½	24 x 8	9.40	25.0	34.0	76.0	85.0	46.3	106.0	4	DN10/15/20	20.0	0.58
¾	29 x 13	15.75	25.0	50.5	87.0	102.0	62.2	114.0	4	1" - 1.5"	17.5	0.90
1	34 x 16	22.10	50.5	50.5	90.0	102.0	62.2	114.0	4	1" - 1.5"	8.5	1.01
1½	48 x 26	34.80	50.5	64.0	105.0	123.0	77.7	127.0	4	2"	8.0	1.19
2	55 x 36	47.50	64.0	77.5	120.0	140.0	91.2	139.0	4	2.5"	7.0	1.53
2½	72 x 33	60.20	77.5	91.0	151.0	150.0	104.7	157.0	6	3"	6.5	1.90
3	108 x 36	72.90	91.0	106.0	175.0	165.0	119.7	171.0	6	3.5"	6.5	2.51
4	135 x 48	97.38	119.0	130.0	200.0	191.0	143.7	194.0	6	4.5"	4.0	3.47

ACL® CT-SVFI – SHX Clamp Type Sterile Visual Flow Indicator

Bill of Materials

Item	Quantity	Description	Material	Available options
1	1	Glass	Borosilicate 3.3	-
2	2	Flange ends	AISI 316L	C22 / AL6XN
3	1	Body	AISI 316L	C22 / AL6XN
4	2	Sealing o-rings	EPDM	FEP / VITON / PC-SIL
5	2	Cushion o-rings	EPDM	FEP / VITON / PC-SIL
6	2	Clamp o-rings	EPDM	FEP / VITON / PC-SIL
7	2	ACL clamps	CF8M / CF8	-

Viewing Window Area – SVFI v CT-SVFI

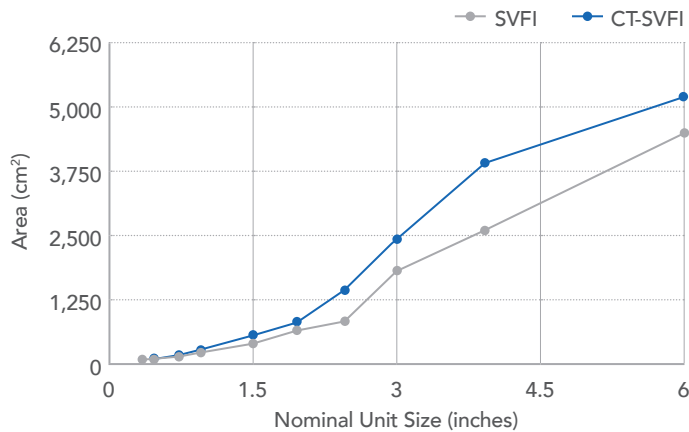

The CT-SVFI has been designed to ensure the largest viewing area possible whilst maintaining the mechanical integrity of the component.

Exploded Assembly

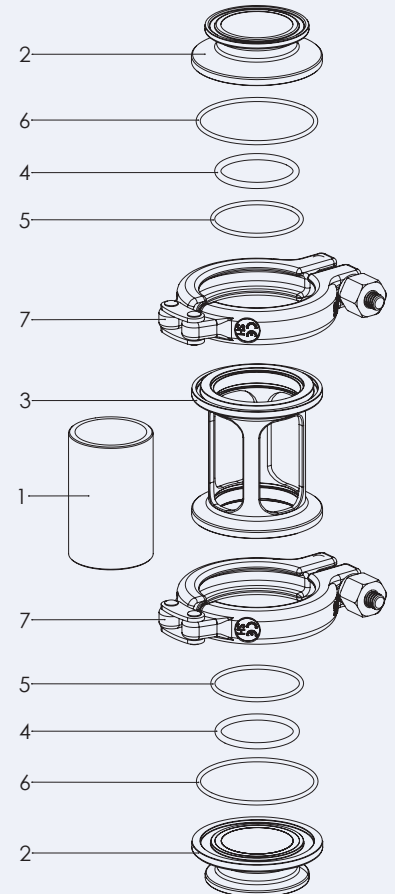

- 1 Glass
- 2 Flange ends
- 3 Body
- 4 Sealing o-rings
- 5 Cushion o-rings
- 6 Clamp o-rings
- 7 ACL® clamps

Seal Layout

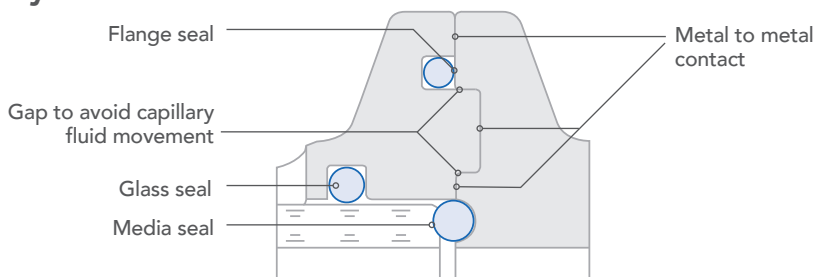

Quality Assurance

The ACL Quality Management System is certified according to EN ISO 9001:2015. We ensure that our suppliers also maintain a certified Quality Management System.

Materials used in the fabrication of the CT-SVFI are European sourced and conform to AD2000 W2 and PED, ensuring the highest level of reliability and safety.

All technical information and advice given here is based on our previous experiences and/or test results. We give this information to the best of our knowledge, but assume no legal responsibility. Customers are asked to check the suitability and usability in the specific application, since the performance of the product can only be judged when all necessary operating data are available. Specifications are subject to change without notice. ACL's terms and conditions of sale apply to the purchase and sale of the product.

Further Information

For detailed selection criteria, technical information, installation guidelines or to contact ACL, please visit our website:

www.advanced-couplings.com

ACL® CT-SVFI – SHX Clamp Type Sterile Visual Flow Indicator

Spare Parts

1/2"

BOM No.	Code	Name	Qty
1	SG.SV.050.G	1/2" SVFI - Glass Element - 40mm long	1
2	SG.SC.050.F	1/2" Clamp Type SVFI Flange Ends - 316L	2
3	SG.SC.050.B	1/2" SVFI Clamp Type Body - 316L	1
4	SG.SV.050.OS	1/2" SVFI - EPDM Small O-Ring	2
5	SG.SV.050.OL	1/2" SVFI - EPDM Large O-Ring	2
6	SG.SC.050.OC	1/2" SVFI - EPDM Clamp O-Ring	2
7	CL.SH.D010	DIN 10/15/20 SH Clamp 316	2

2 1/2"

BOM No.	Code	Name	Qty
1	SG.SV.250.G	2 1/2" SVFI - Glass Element - 86mm Long	1
2	SG.SC.250.F	2 1/2" SVFI Clamp Type Flange Ends - 316L	2
3	SG.SC.250.B	2 1/2" SVFI Clamp Type Body - 316L	1
4	SG.SV.250.OS	2 1/2" SVFI - EPDM Small O-Ring	2
5	SG.SV.250.OL	2 1/2" SVFI - EPDM Large O-Ring	2
6	SG.SC.250.OC	2 1/2" SVFI - EPDM Clamp O-Ring	2
7	CL.SH.0300	3" SH Clamp 316	2

3/4"

BOM No.	Code	Name	Qty
1	SG.SV.075.G	3/4" SVFI - Glass Element - 47mm Long	1
2	SG.SC.075.F	3/4" Clamp Type SVFI Flange Ends - 316L	2
3	SG.SC.075.B	3/4" SVFI Clamp Type Body - 316L	1
4	SG.SV.075.OS	3/4" SVFI - EPDM Small O-Ring	2
5	SG.SV.075.OL	3/4" SVFI - EPDM Large O-Ring	2
6	SG.SV.150.OL	1 1/2" SVFI - EPDM Large O-Ring	2
7	CL.SH.0100	1" - 1 1/2" SH Clamp 316	2

3"

BOM No.	Code	Name	Qty
1	SG.SV.300.G	3" FVFI - Glass Element - 122.5mm Long	1
2	SG.SC.300.F	3" SVFI Clamp Type Flange Ends - 316L	2
3	SG.SC.300.V	3" SVFI Clamp Type Body - 316L	1
4	SG.SC.300.OS	3" SVFI - EPDM Seal O-Ring	2
5	SG.SV.300.OL	3" SVFI - EPDM Large O-Ring	2
6	SG.SC.300.OC	3" SVFI - EPDM Clamp O-Ring	2
7	CL.SH.0350	3 1/2" SH Clamp 316	2

1"

BOM No.	Code	Name	Qty
1	SG.SV.100.G	1" SVFI - Glass Element - 50mm Long	1
2	SG.SC.100.F	1" SVFI Clamp Type Flange Ends - 316L	2
3	SG.SC.100.B	1" SVFI Clamp Type Body - 316L	1
4	SG.SV.100.OS	1" SVFI - EPDM Small O-Ring	2
5	SG.SV.100.OL	1" SVFI - EPDM Large O-Ring	2
6	SG.SV.150.OL	1 1/2" SVFI - EPDM Large O-Ring	2
7	CL.SH.0100	1" - 1 1/2" SH Clamp 316	2

4"

BOM No.	Code	Name	Qty
1	SG.SV.400.G	4" SVFI - Glass Element - 147.5mm Long	1
2	SG.SC.400.F	4" SVFI Clamp Type Flange Ends - 316L	2
3	SG.SC.400.B	4" SVFI Clamp Type Body - 316L	1
4	SG.SV.400.OS	4" SVFI - EPDM Small O-Ring	2
5	SG.SV.400.OL	4" SVFI - EPDM Large O-Ring	2
6	SG.SC.400.OC	4" SVFI - EPDM Clamp O-Ring	2
7	CL.SH.0450	4 1/2" SH Clamp 316	2

1 1/2"

BOM No.	Code	Name	Qty
1	SG.SV.150.G	1 1/2" SVFI - Glass Element - 64mm Long	1
2	SG.SC.150.F	1 1/2" SVFI Clamp Type Flange Ends - 316L	2
3	SG.SC.150.B	1 1/2" SVFI Clamp Type Body - 316L	1
4	SG.SV.150.OS	1 1/2" SVFI - EPDM Small O-Ring	2
5	SG.SV.150.OL	1 1/2" SVFI - EPDM Large O-Ring	2
6	SG.SC.150.OC	1 1/2" SVFI - EPDM Clamp O-Ring	2
7	CL.SH.0200	2" SH Clamp 316	2

6"

BOM No.	Code	Name	Qty
1	SG.FV.600.G	6" FVFI - Glass Element	1
2	SG.SC.600.F	6" SVFI Clamp Type Flange Ends - 316L	2
3	SG.SC.600.B	6" SVFI Clamp Type Body - 316L	1
4	SG.SV.600.OS	6" SVFI - EPDM Small O-Ring	2
5	SG.SV.600.OL	6" SVFI - EPDM Large O-Ring	2
6	SG.SC.600.OC	6" SVFI - EPDM Clamp O-Ring	2
7	CL.SH.0658	6 5/8" SH Clamp 316 (Single Bolt)	2

2"

BOM No.	Code	Name	Qty
1	SG.SV.200.G	2" SVFI - Glass Element - 70mm Long	1
2	SG.SC.200.F	2" SVFI Clamp Type Flange Ends - 316L	2
3	SG.SC.200.B	2" SVFI Clamp Type Body - 316L	1
4	SG.SV.200.OSN	2" SVFI - EPDM Small O-Ring	2
5	SG.SV.200.OL	2" SVFI - EPDM Large O-Ring	2
6	SG.SC.200.OC	2" SVFI - EPDM Clamp O-Ring	2
7	CL.SH.0250	2 1/2" SH Clamp 316	2